

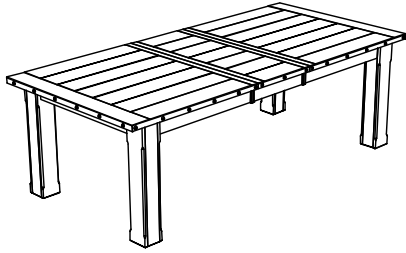

DINING TABLE / TABLE SALLE A MANGER



IMPORTANT NOTE :

- Place all wooden parts on a clean and smooth surface such as a rug or carpet to avoid the parts from being scratched.
- Check to be sure that you have all parts and hardware.
- Remove all wrapping materials, including staples & packing straps before you start to assemble.
- Do not tighten all screws / bolts until all completely assembled.
- Keep all hardware parts out of reach of children.

| COMPONENT LIST / LISTE DE PIECES | | |
|----------------------------------|-----------------------------|---------|
| NO | DESCRIPTION | QTY/PCS |
| 1 | TABLE TOP / DESSUS DE TABLE | 1 PC |
| 2 | TABLE LEAF / RALLONGE | 1 PC |
| 3 | LEG / PIED | 4 PCS |

| HARDWARE LIST / LISTE DE QUINCAILLERIE | | |
|--|--|---------|
| NO | DESCRIPTION | QTY/PCS |
| A | BOLT / BOULON M8 x 60 | 8 PCS |
| B | SPRING WASHER RONDELLE D'ARRET 5/16" | 8 PCS |
| C | FLAT WASHER / RONDELLE PLATE 5/16" x 22 | 8 PCS |
| D | ALLEN KEY / CLE' ALLEN M5 | 1 PC |

*HARDWARE SET IS IN 5400-94 FOR ASSEMBLY

NOTE : YOU WILL ALSO NEED A PHILIP SCREW DRIVER (NOT PROVIDED)

STEP 1 / ETAPE 1

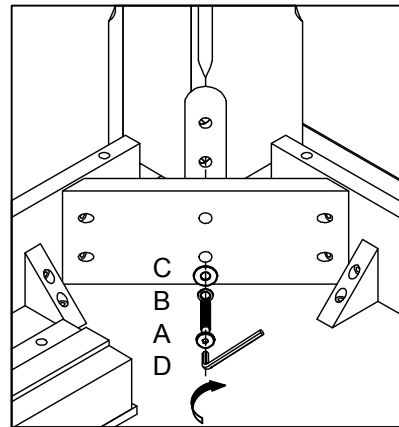
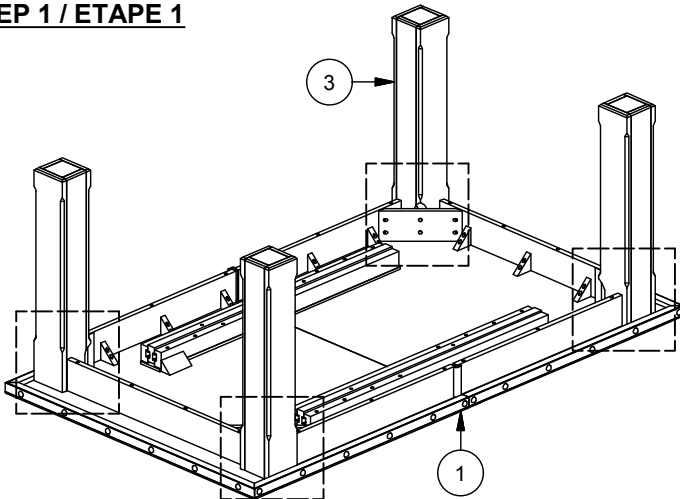

STEP 2 / ETAPE 2

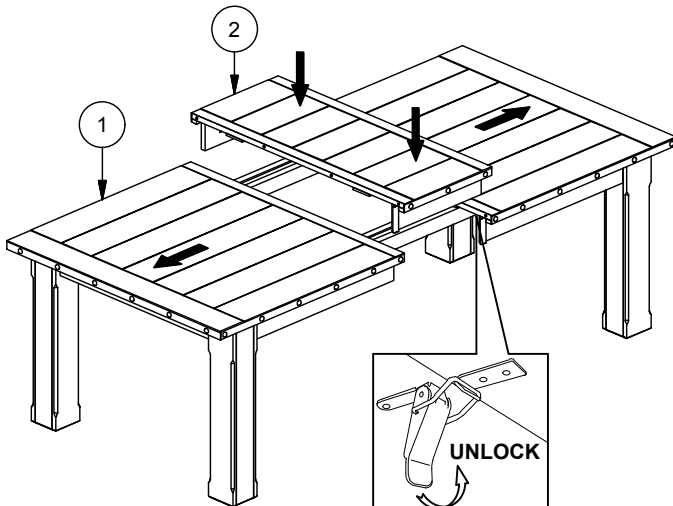

STEP 3 / ETAPE 3

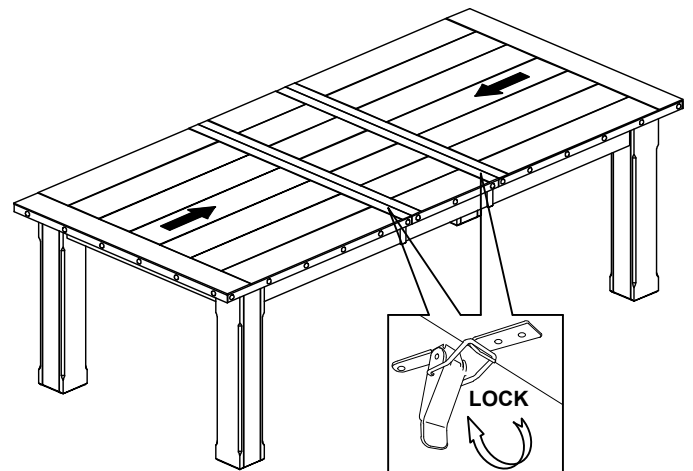

For items use on wooden floor, hard surfaces or carpets, its is recommended to install protective pads under all legs and supports to avoid/prevent from damages/scratches and discoloration.



Pour les articles utilises sur un plancher en bois, des surfaces dures ou tapis, il est recommande d'installer des mordaches de protection sous tous les jambes et prend en charge pour eviter/empêcher de dommages/rajuures et la decoloration.