

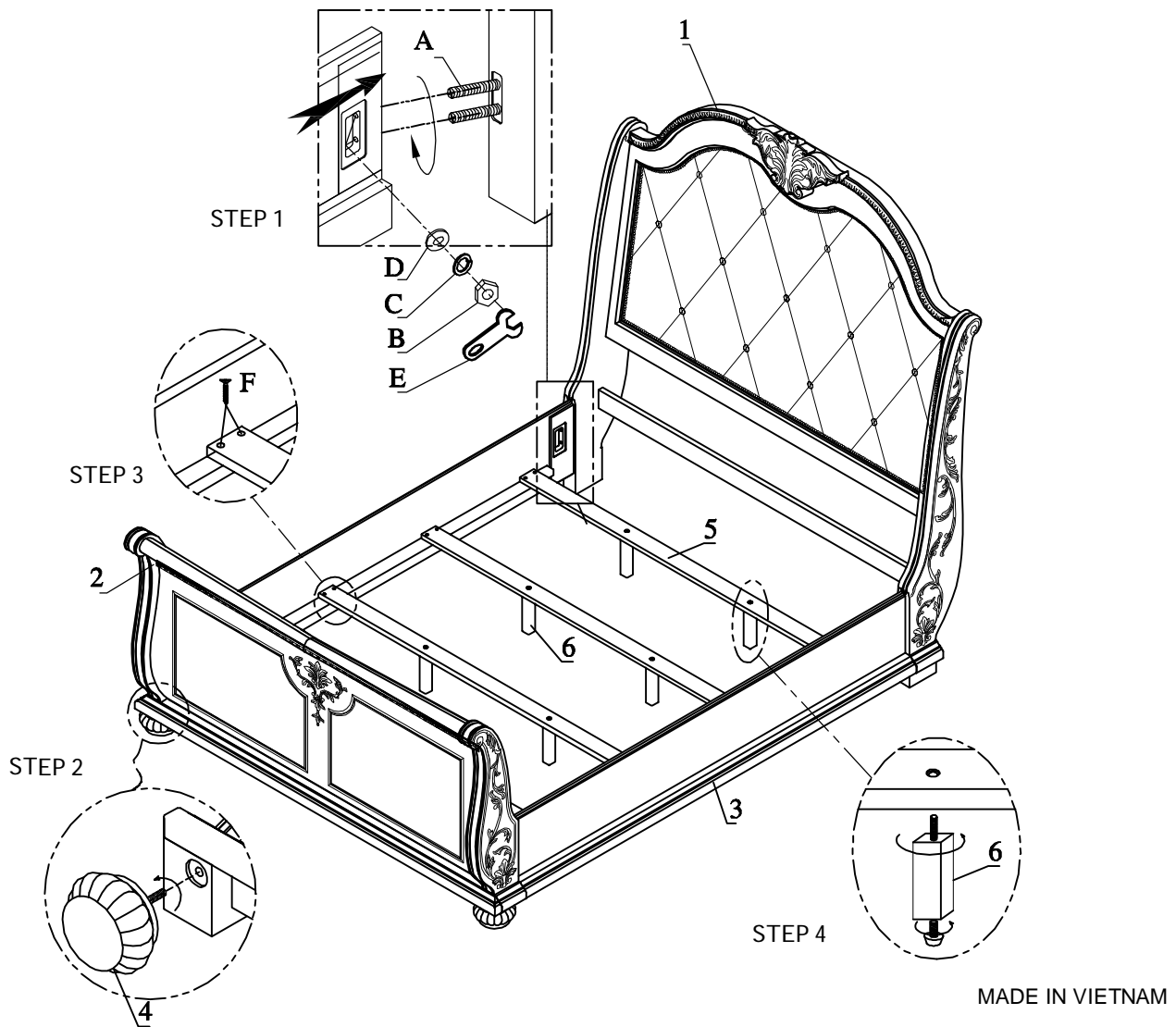

H O M E E L E G A N C E

ITEM: 2169SLK-1EK-2EK-3EK
EASTERN KING BED

Thank you for purchasing this quality product. Be sure to check all packing material carefully for small parts which may have come loose inside the carton during shipment. Identify and count all parts and compare with the Parts List below.



MADE IN VIETNAM

PARTS LIST

NO.	Q'TY	DESCRIPTION
1	1	HEADBOARD
2	1	FOOTBOARD
3	2	SIDE RAIL
4	2	BUN FOOT
5	4	SLAT
6	8	SUPPORT LEG

HARDWARE LIST

NO.	DRAWING	Q'TY	DESCRIPTION
A		8 PCS	Φ5/16" *3-1/2" BOLT
B		8 PCS	Φ5/16" HET NUT
C		8 PCS	Φ5/16" LOCK WASHER
D		8 PCS	Φ5/16" *19mm FLAT WASHER
E		1 PC	Ø5/16" OPEN WRENCH
F		16 PCS	#8*1" WOOD SCREW